

Knife Gate Valve

# HERA-BHT

PN 10/16, Class 150  
DN 80-600

## Type Series Booklet



## **Legal information/Copyright**

Type Series Booklet HERA-BHT

All rights reserved. The contents provided herein must neither be distributed, copied, reproduced, edited or processed for any other purpose, nor otherwise transmitted, published or made available to a third party without the manufacturer's express written consent.

Subject to technical modification without prior notice.

© KSB Valves Changzhou Co., Ltd., China 18/01/2018

---

## Contents

<b>Knife Gate Valves</b> .....	<b>4</b>
Bi-directional Knife Gate Valve .....	4
HERA-BHT .....	4
Main applications.....	4
Fluids handled .....	4
Operating data.....	4
Body materials.....	4
Design details .....	4
Product benefits.....	4
Related documents .....	5
Purchase order specifications .....	5
Pressure/temperature ratings.....	5
Materials.....	5
Dimensions and weights.....	7

## Knife Gate Valves

### Bi-directional Knife Gate Valve

## HERA-BHT



#### Main applications

- Pulp and paper industry
- Solids separation
- Hydraulic repulping
- Transport of mining slurry
- Drainage systems
- Sludge disposal
- Sludge processing
- Transport of residues
- Waste water treatment plants

#### Fluids handled

- Slurry
- High-density fluids
- Solids-laden fertiliser fluids
- Pulp
- Digested sludge
- Raw sludge
- Activated sludge
- Waste water
- Service water
- Other fluids on request.

#### Operating data

##### Operating properties

Characteristic	Value
Nominal pressure	PN 10/16,
Nominal pressure	Class 150
Nominal size	DN 80 - 600
Max. permissible pressure [bar]	10,3
Min. permissible temperature [°C]	-10
Max. permissible temperature [°C]	+100

#### Body materials

##### Overview of available materials

Material	Temperature limit
ASTM A 216 WCB	≤ 425 °C
ASTM A 351 CF8	≤ 538 °C
ASTM A 351 CF8M	≤ 538 °C

Other materials on request.

#### Design details

##### Design

- Design to ASME B16.34 and MSS SP-81
- Semi-lug body
- Two-piece body with integrated flange seal
- Rising stem
- Non-rising handwheel
- Welded steel plate construction (DN 450-600)
- Bi-directional and soft-seated
- Through-going blade with excellent flow characteristic
- Robust yoke for actuator mounting as standard
- The valves satisfy the safety requirements of Annex I of the European Pressure Equipment Directive 2014/68/EU (PED) for fluids in Group 2.
- The valves can be used in potentially explosive atmospheres, Group II, category 2 (zones 1+21) and category 3 (zones 2+22) to ATEX 2014/34/EU.

##### Variants

- Double-acting pneumatic actuators
- Electric actuators
- Locking device
- Stem extension
- Stem protecting tube
- Position indicator
- Chain wheel
- Mechanical limit switch
- Larger nominal sizes and other variants on request

##### Product benefits

- Cast steel body withstands elevated fluid pressures.
- Yoke replaceable to accommodate different actuators quickly and easily.
- Gate valve bore is identical with nominal pipe diameter, resulting in a low flow resistance and process cost savings.

- Two-piece body without dead volumes: no downtime and maintenance costs caused by the removal of solids deposits.
- Reliable sealing: O-ring-supported self-adjusting flexible seat with high abrasion resistance and long service life.
- Suitable for universal use. Metal-seated and soft-seated (PTFE and EPDM) designs available to suit a variety of processes.

**Purchase order specifications**

Please specify the following information in all enquiries or purchase orders:

1. Type
2. Nominal pressure
3. Nominal size
4. Operating pressure
5. Operating temperature
6. Fluid handled
7. Variants
8. Reference number

**Related documents**

Information/documents

Document	Reference number
Type series booklet HERA-BD (knife gate valve, bi-directional)	7328.1
Type series booklet HERA-BDS (knife gate valve, bi-directional)	7332.1
Type series booklet HERA-SH (knife gate valve, uni-directional)	7329.1
Operating manual	7330.8

**Pressure/temperature ratings**

Test pressure and operating pressure

PN	DN	Shell test <sup>1)</sup>	Leak test (seat) <sup>1)</sup>	Permissible operating pressure
		With water		
		[bar]	[bar]	[bar]
10	80-600	15	2,8	10,3
16	80-600	24	2,8	10,3
Class 150	80-600	30	2,8	10,3

**Materials**

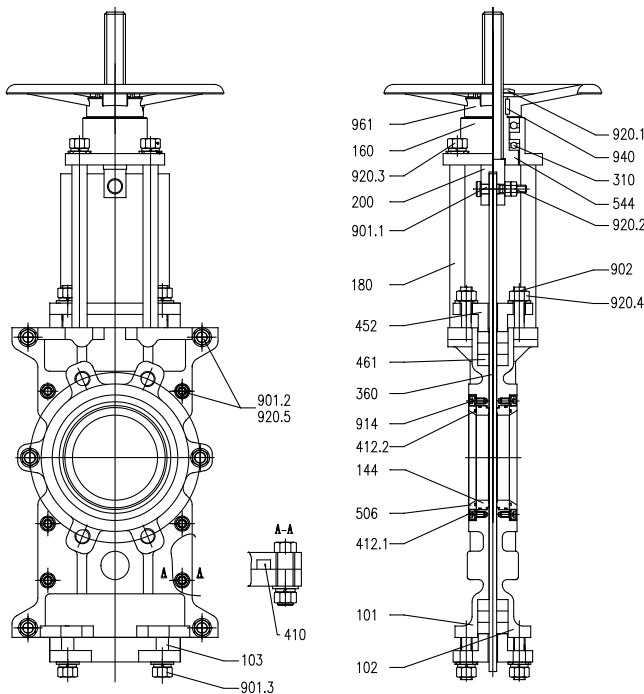

HERA-BHT

1) Test procedure to MSS SP-81

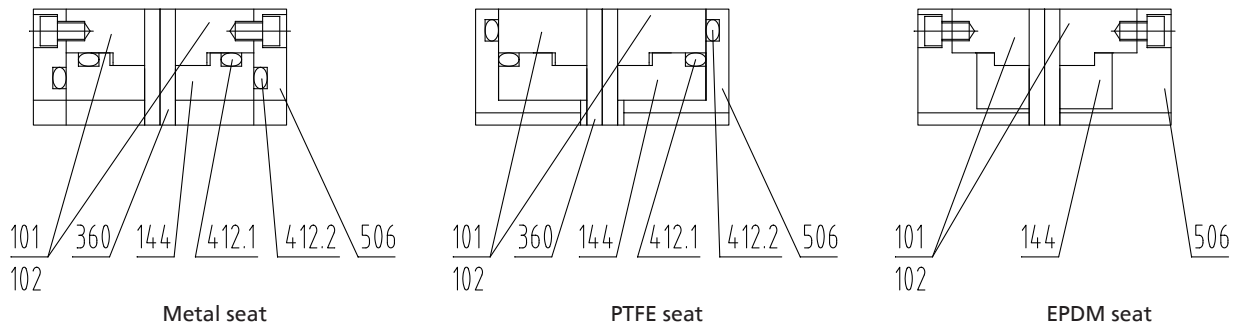

**Parts list**

Part No.	Description	Material	Note
101	Lower body section	ASTM A 216 WCB	-
		ASTM A 351 CF8	-
		ASTM A 351 CF8M	-
102	Upper body section	ASTM A 216 WCB	-
		ASTM A 351 CF8	-
		ASTM A 351 CF8M	-
103	Bottom plate	ASTM A 216 WCB	-
		ASTM A 351 CF8	-
		ASTM A 351 CF8M	-
144	Seat	ASTM A 182 F304 + HCr	For metal-seated design
		ASTM A 182 F316 + HCr	For metal-seated design
		EPDM	-20 °C to +120 °C
		PTFE	-20 °C to +150 °C
160	Cover	Aluminium alloy	-
180	Pillar	ASTM A 182 F304	For body made of A 351 CF8(M)
		C45 + Cr	For body made of A 216 WCB
200	Stem	ASTM A 182 F304	-
310	Plain bearing	GCr6	-
360	Blade	ASTM A 182 F304	For soft-seated design
		ASTM A 182 F304 + HCr	For metal-seated design
		ASTM A 182 F316	For soft-seated design
		ASTM A 182 F316 + HCr	For metal-seated design
		ASTM A 276 410 + HCr	For soft-seated and metal-seated designs
410	Sealing element	NBR	-20 °C to +100 °C
412.1	O-ring	NBR	-20 °C to +100 °C
		Viton	-20 °C to +180 °C
412.2	O-ring	NBR	-20 °C to +100 °C
		Viton	-20 °C to +180 °C
452	Gland follower	ASTM A 216 WCB	-
		ASTM A 351 CF8	-
		ASTM A 351 CF8M	-
461	Gland packing	NBR or Viton	-
506	Retaining ring	ASTM A 216 WCB	-
		ASTM A 351 CF8	-
		ASTM A 351 CF8M	-
544	Threaded bush	H59	-
901.1	Bolt	ASTM A 182 F304	-
901.2	Bolt	ASTM A 182 F304	-
901.3	Bolt	ASTM A 182 F304	-
914	Hexagon socket head cap screw	ASTM A 182 F304	-
920.1	Nut	ASTM A 182 F304	-
920.2	Nut	ASTM A 182 F304	-
920.3	Nut	ASTM A 182 F304	-
940	Key	C45	-
961	Handwheel	D-2	-

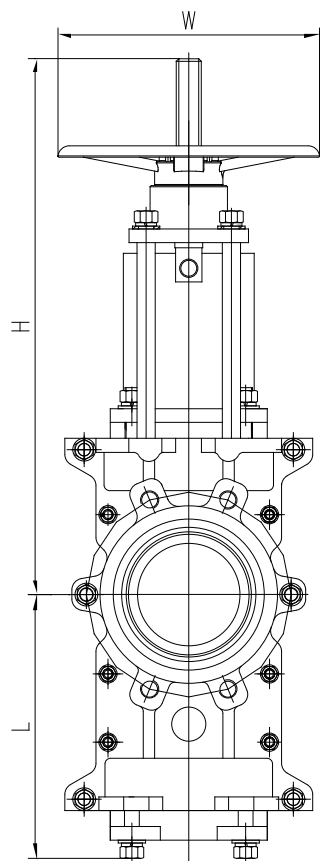
Dimensions and weights

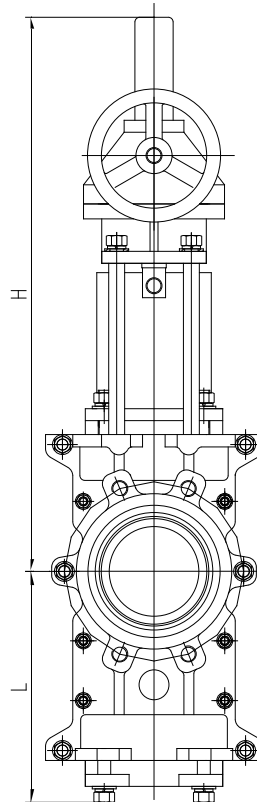
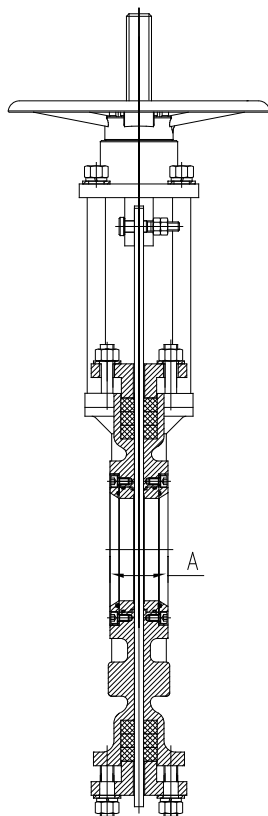

HERA-BHT with handwheel



HERA-BHT with gearbox

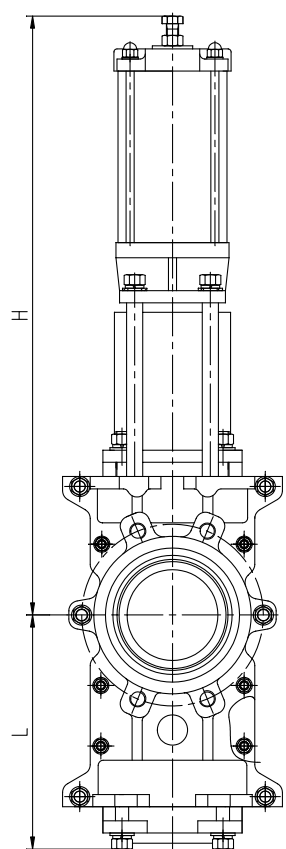
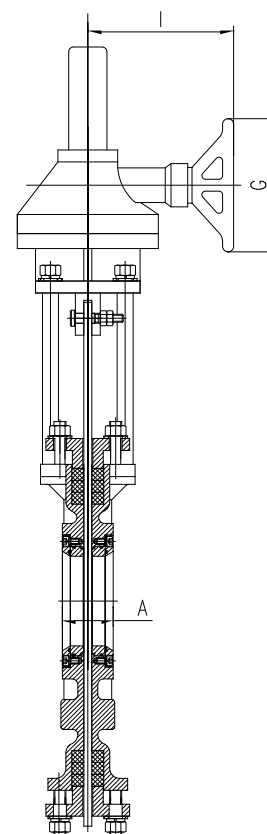

HERA-BHT with pneumatic actuator

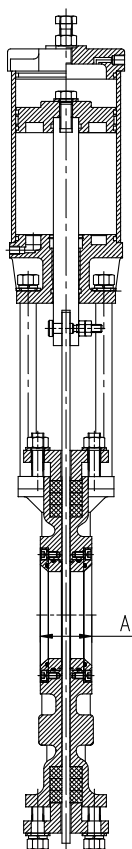

- 2) Fully open
- 3) Welded design

**Dimensions [mm] and weights [kg]**

PN	DN	A	L	H <sup>2)</sup>	W	G	I	H1	With handwheel	With gearbox	With pneumatic actuator
									[kg]	[kg]	[kg]
10/16 Class 150	80	51	250	480	220	-	-	610	15,0	-	22,0
	100	51	350	530	220	-	-	620	17,0	-	24,5
	125	57	410	615	250	-	-	755	24,5	-	36,0
	150	57	450	695	280	-	-	800	31,0	-	44,3
	200	70	570	820	315	-	-	1000	53,5	-	72,4
	250	70	630	990	355	-	-	1170	74,0	-	107,8
	300	76	710	1140	400	-	-	1350	120,0	-	173,8
	350	76	810	1300	450	-	-	1570	185,0	-	315,0
	400	89	910	1570	-	310	260	1700	291,0	-	406,0
	450 <sup>3)</sup>	110	1000	1810	-	460	340	1940	-	422,0	625,0
500 <sup>3)</sup>	114	1110	1910	-	460	340	2050	-	480,0	714,0	
600 <sup>3)</sup>	134	1280	2190	-	460	340	2350	-	915,0	1195,0	

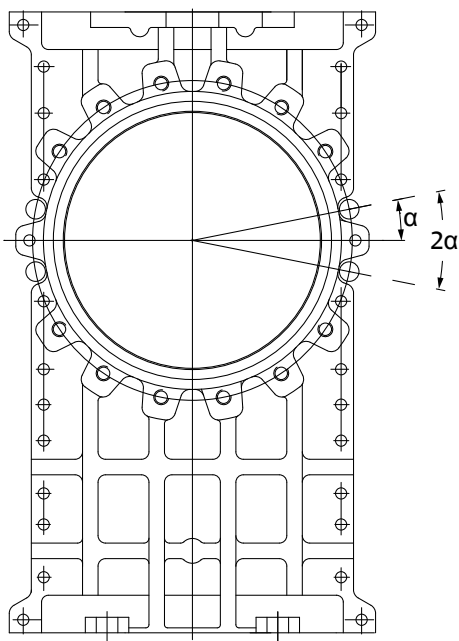

DN 80-400 (semi-lug type)

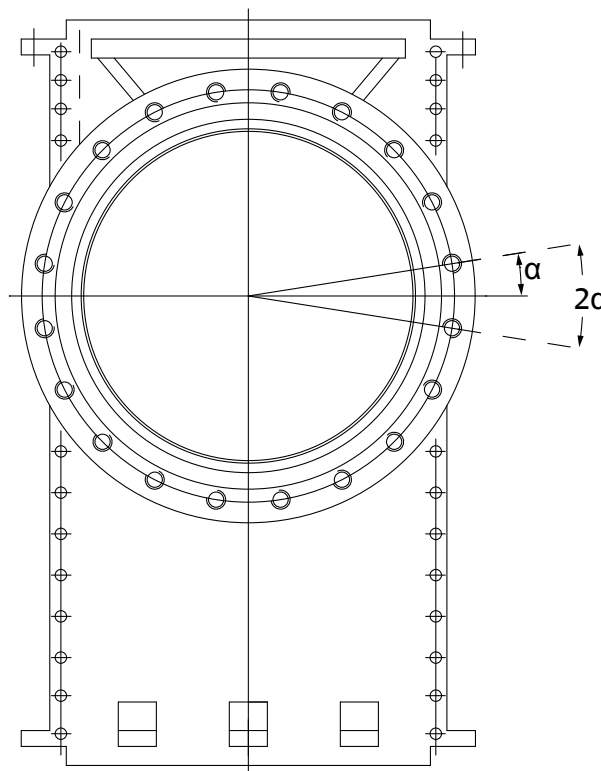

DN 450-600 (full-lug type)

**Dimensions [mm]**

PN	DN	Flange OD	Bolt circle diameter	Number of clearance holes	Number of tapped holes
10	80	200	160	4	4
	100	220	180	4	4
	125	250	210	4	4
	150	285	240	4	4
	200	340	295	4	4
	250	395	350	4	8
	300	445	400	4	8
	350	505	460	4	12
	400	565	515	4	12
	450	615	565	0	20
16	80	200	160	4	4
	100	220	180	4	4
	125	250	210	4	4
	150	285	240	4	4
	200	340	295	4	8
	250	405	355	4	8



PN	DN	Flange OD	Bolt circle diameter	Number of clearance holes	Number of tapped holes
16	300	460	410	4	8
	350	520	470	4	12
	400	580	525	4	12
	450	640	585	0	20
	500	715	650	0	20
	600	840	770	0	20

**Dimensions [mm]**

PN	DN	Depth of tapped holes	Bolt size	Bolt hole ID	Angle $\alpha$
10	80	14	M16	18	22,50°
	100	14	M16	18	22,50°
	125	16	M16	18	22,50°
	150	16	M20	22	22,50°
	200	16	M20	22	22,50°
	250	16	M20	22	15,00°
	300	18	M20	22	15,00°
	350	20	M20	22	11,25°
	400	20	M24	26	11,25°
	450	24	M24	26	9,00°
	500	24	M24	26	9,00°
16	80	14	M16	18	22,50°
	100	14	M16	18	22,50°
	125	16	M16	18	22,50°
	150	16	M20	22	22,50°
	200	16	M20	22	15,00°
	250	16	M24	26	15,00°
	300	18	M24	26	15,00°
	350	20	M24	26	11,25°
	400	20	M27	30	11,25°
	450	24	M27	30	9,00°
	500	24	M30	33	9,00°
600	30	M33	36	9,00°	

**Dimensions [mm]**

Class	DN	Flange OD	Bolt circle diameter	Number of clearance holes	Number of tapped holes
150	3"	190	152,5	0	4
	4"	230	190,5	4	4
	5"	255	216,0	4	4
	6"	280	241,5	4	4
	8"	345	298,5	4	4
	10"	405	362,0	4	8
	12"	485	432,0	4	8
	14"	535	476,0	4	8
	16"	600	540,0	4	12
	18"	635	578,0	0	16
	20"	700	635,0	0	20
	24"	815	749,5	0	20

**Dimensions [mm]**

Class	DN	Depth of tapped holes	Bolt size	Bolt hole ID	Angle $\alpha$
150	3"	14	$\frac{5}{8}$ " - 11 UNC	18,0	45,00°
	4"	14	$\frac{5}{8}$ " - 11 UNC	18,0	22,50°
	5"	16	$\frac{3}{4}$ " - 10 UNC	22,0	22,50°
	6"	16	$\frac{3}{4}$ " - 10 UNC	22,0	22,50°
	8"	16	$\frac{3}{4}$ " - 10 UNC	22,0	22,50°
	10"	16	$\frac{7}{8}$ " - 9 UNC	26,0	15,00°
	12"	18	$\frac{7}{8}$ " - 9 UNC	26,0	15,00°
	14"	20	1" - 8 UNC	29,5	15,00°
	16"	20	1" - 8 UNC	29,5	11,25°
	18"	24	1 $\frac{1}{8}$ " - 7 UNC	32,5	11,25°
	20"	24	1 $\frac{1}{8}$ " - 7 UNC	32,5	9,00°

Class	DN	Depth of tapped holes	Bolt size	Bolt hole ID	Angle $\alpha$
150	24"	30	1 1/4" - 7 UNC	35,5	9,00°

**Mating dimensions as per standard**

Face-to-face lengths: MSS SP-81  
 Flanges: Mating dimensions to  
 EN 1092-1 (PN 10/16)  
 ASME B16.5 (Class 150)





**KSB SE & Co. KGaA**  
Johann-Klein-Straße 9 • 67227 Frankenthal (Germany)  
Tel. +49 6233 86-0  
[www.ksb.com](http://www.ksb.com)